

HIGH SIDE DRIVING WITH TD310

by R. LIOU

INTRODUCTION

The TD310 is a triple MOS or IGBT driver which integrates all functions suited for compact and highly secure driving such as adjustable Under Voltage Lockout feature (UVLO), sense comparator with alarm output and automatic shutdown, independent operational amplifier, enable pin, and global standby mode (e.g.: for portable applications).

Its wide operating supply voltage range makes it appropriate in many different applications, in particular in 12V supplied automotive field.

The following shows how secure high side driving is easily achievable using few external and low cost components in very common lamp high side driving applications.

PRINCIPLE

The Op Amp is used as an oscillator by means of the R1C1 backloop (blinker frequency ~1Hz) and enables/disables the charge pump that drives the high side MOS Q1.

The charge pump is made using one of the three inverting buffers mounted as an oscillator with the R2C2 backloop (charge pump frequency ~100kHz). The capacitor C is used to transfer the buffer high state voltage to the gate of Q1.

The diode D1 refrains the gate from discharging and the diode D2 shifts the voltage across C above the source of Q1.

Figure 1 shows the blinker application schematic, and figures 2 and 3 show the resulting traces:

- trace 1 : the Op Amp output
- trace 2 : the inverting buffer output
- trace 3 : the transistor Q1 gate (low Ron)
- trace 4 : the load (12V/21W lamp)

Figure 1

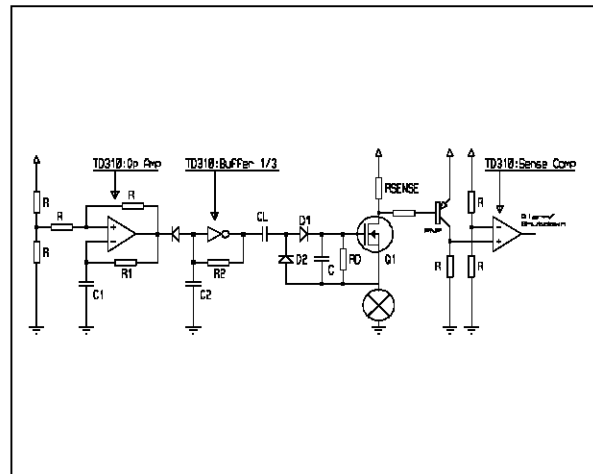

Figure 2

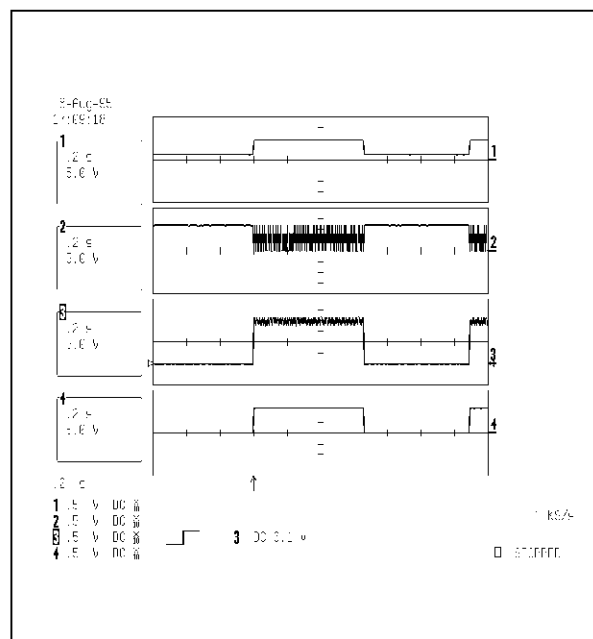
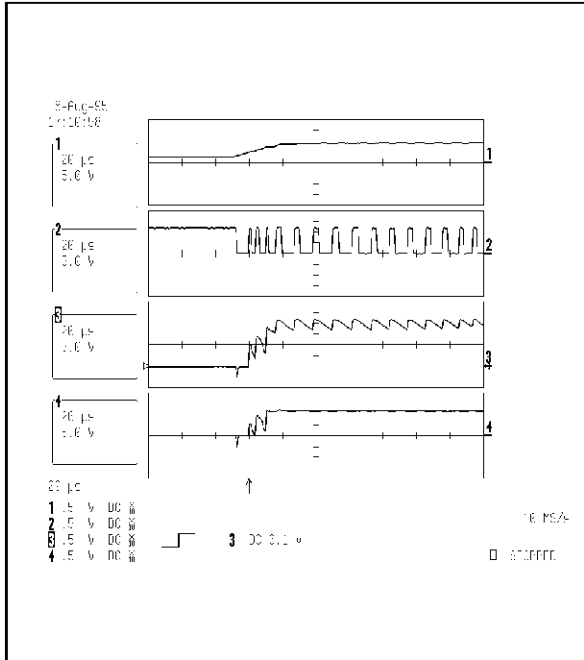

Figure 3



The sense comparator is used with a high side sense resistor and a PNP transistor for over current/short circuit detection and shuts all buffers at low state and the Op Amp at high impedance as soon as the voltage across Rsense passes 0.6V.

DESIGN CONSIDERATIONS

The capacitor CL value should be higher than the input capacitance of the transistor Q1, but not too high to ensure the best efficiency for the charge pump (CL~10nF).

The resistor Rd should be chosen considering that the higher Rd is, the faster Q1 is switched on; the lower Rd is, the faster Q1 is switched off and the efficiency of the charge pump is deteriorated, thus increasing the consumption. If Rd is low, a capacitor C is needed (Rd~5kΩ, C~10nF).

The switching on is also to be put in relation with the charge pump frequency which should be as high as possible, but it must be kept in mind that the commutation losses cannot be neglected at high frequencies.

Note 1 :

The application described above can be implemented in a load dump protected environment as shown on figure 4.

Figure 4

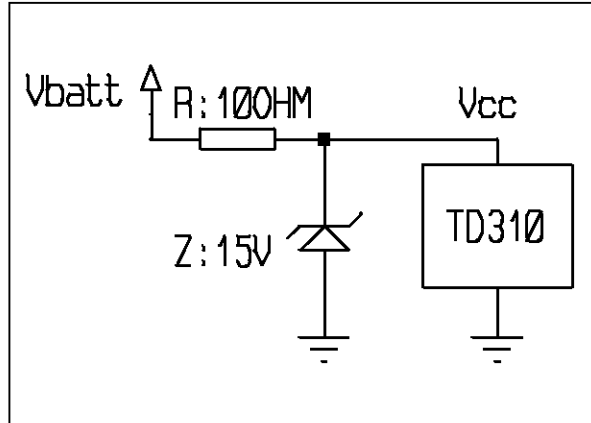

Note 2 :

With the charge pump described, it is possible to drive the high side MOS under high voltage, with the mere supply voltage of TD310, provided that CL capacitor holds this high voltage (e.g.: 600V).

Note 3 :

The application described requires only one of the three available buffers and neither the enable pin, nor the standby mode is used, thus offering a number of other possibilities in many different environments.

Figure 5 shows a simple timing function for delayed switching off of a lamp (e.g.: ceiling lamp).

Figure 5

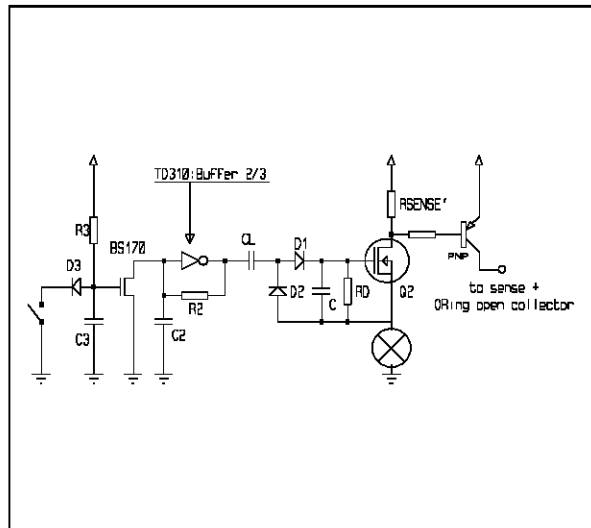
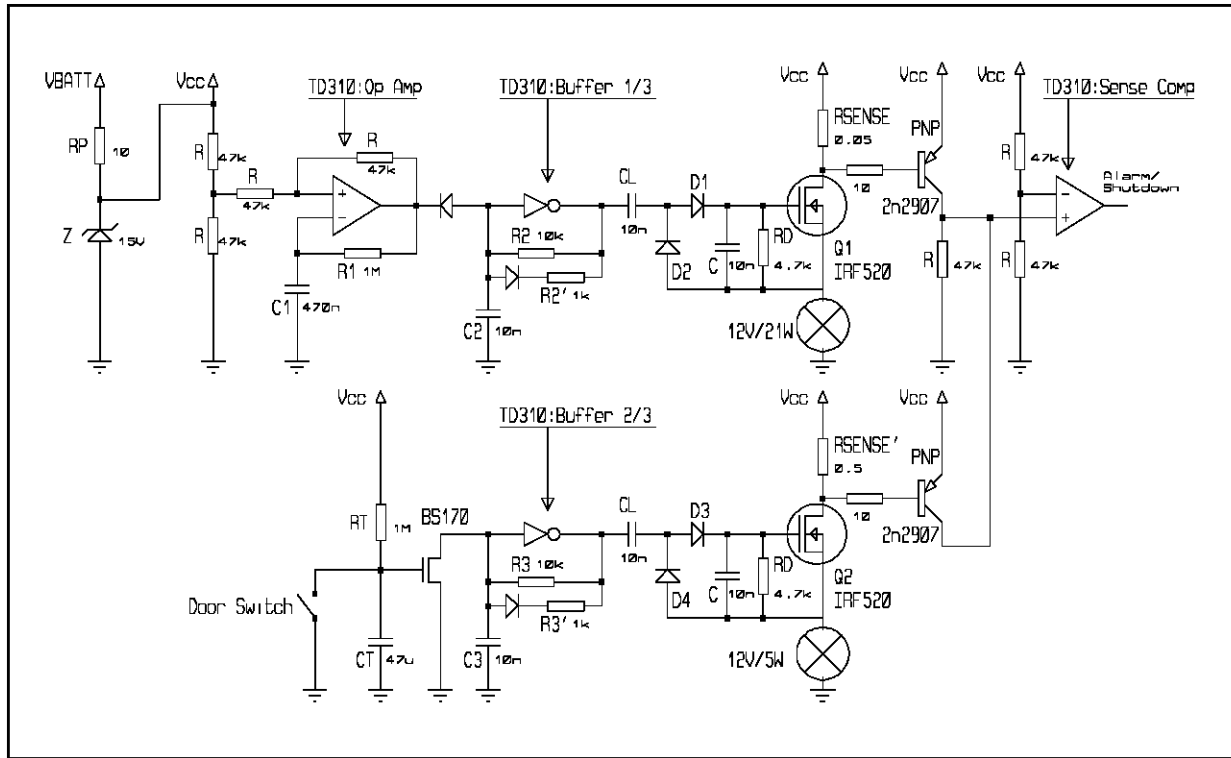

Figure 6 shows the ready to use applications (blinker and timing functions) described above where both applications are short circuit protected by the same sense comparator.

The resistor R2' and diode have been added to balance the duty cycle of the 100kHz oscillator.

Figure 6



Information furnished is believed to be accurate and reliable. However, SGS-THOMSON Microelectronics assumes no responsibility for the consequences of use of such information nor for any infringement of patents or other rights of third parties which may result from its use. No licence is granted by implication or otherwise under any patent or patent rights of SGS-THOMSON Microelectronics. Specifications mentioned in this publication are subject to change without notice. This publication supersedes and replaces all information previously supplied. SGS-THOMSON Microelectronics products are not authorized for use as critical components in life support devices or systems without express written approval of SGS-THOMSON Microelectronics.

© 1996 SGS-THOMSON Microelectronics - All Rights Reserved

SGS-THOMSON Microelectronics GROUP OF COMPANIES

Australia - Brazil - France - Germany - Hong Kong - Italy - Japan - Korea - Malaysia - Malta - Morocco - The Netherlands
Singapore - Spain - Sweden - Switzerland - Taiwan - Thailand - United Kingdom - U.S.A.

ORDER CODE: